

GP Batteries

Data Sheet

Model No.: VPL005

Document Number: SDS0474

Revision: 00

Page 1 of 3

Specifications:

Model No	:	VPL005
For use with	:	Panasonic PV-DV200, PV-DV400, PV-DV600, PV-DV800, PV-DV851, PV-DV900, PV-DV901, PV-DV910, PV-DV951, PV-DV952
Color	:	Black (BLK)
Battery Type	:	Lithium Ion
Battery	:	4 × GP1750L100
Nominal Voltage	:	7.4V
Maximum Charge Voltage	:	8.4V
Discharge Cut Off Voltage	:	5.6V
Typical Capacity	:	2000mAh at 0.2C**
Minimum Capacity	:	1800mAh at 0.2C**
Temperature Range	:	Charge: 0 ~ 45°C Discharge: -20 ~ 60°C Storage: -20 ~ 45°C
Casing Material	:	ABS + PC
Typical Weight	:	125g
Safety	:	Each battery pack has a protection circuit & thermistor that would protect against over-voltage, over-discharge and over-current abuses occur. Every Lithium Ion cell is provided with several internal safety features to prevent over-charge, over-current, and to resist physical abuse. Each has a temperature sensitive shut down separator, pressure sensitive tear away tab for current interruption, a safety vent, and the industries only temperature actuated current interrupter.
Warranty	:	Six (6) months limited warranty from date of purchase.

**' Data valid only when the battery pack is on fully charged condition.

***' Battery pack should be firstly charged and discharged for 3 complete cycles as a warm-up.

(Details refer to Lithium-Ion Battery Product Specification.)

Brand names of camcorders are registered trademarks of the respective manufacturers.

GP Batteries

Data Sheet

Model No.: VPL005

Document Number: SDS0474

Revision: 00

Page 2 of 3

Mechanical Drawing:

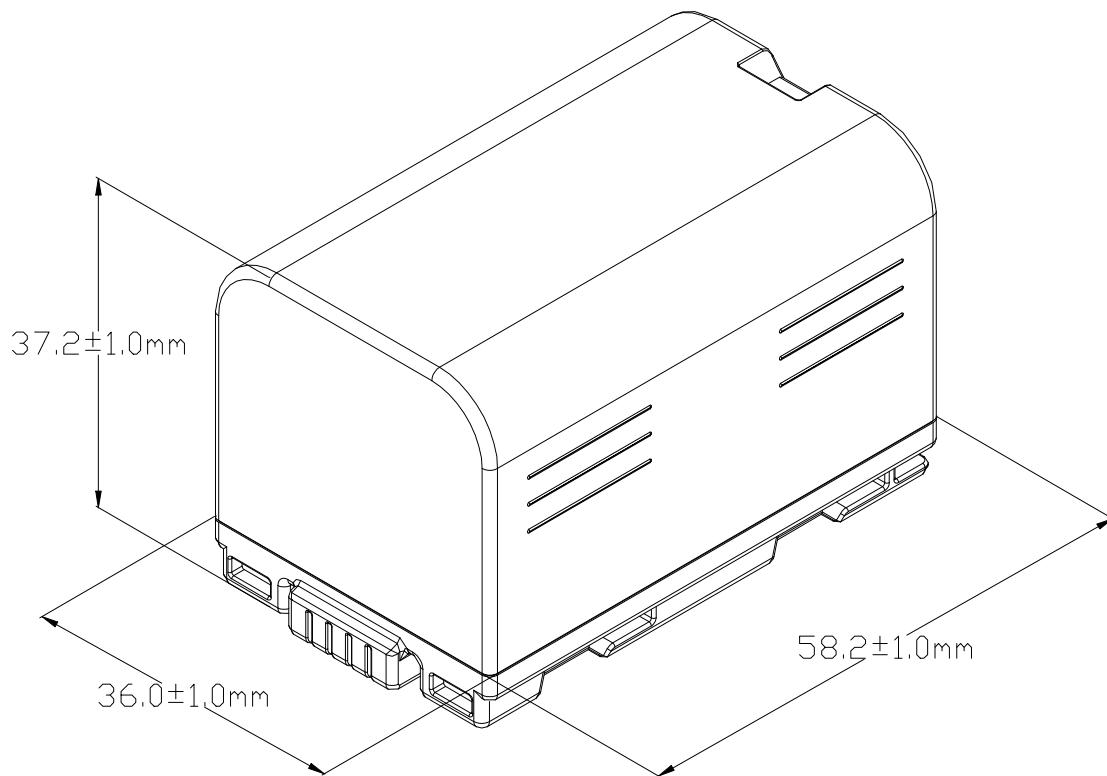

Remark: Dimensions showed are for reference only. For detail, please refer to the engineering drawing.

GP Batteries

Data Sheet

Model No.: VPL005

Document Number: SDS0474

Revision: 00

Page 3 of 3

Circuit Diagram:

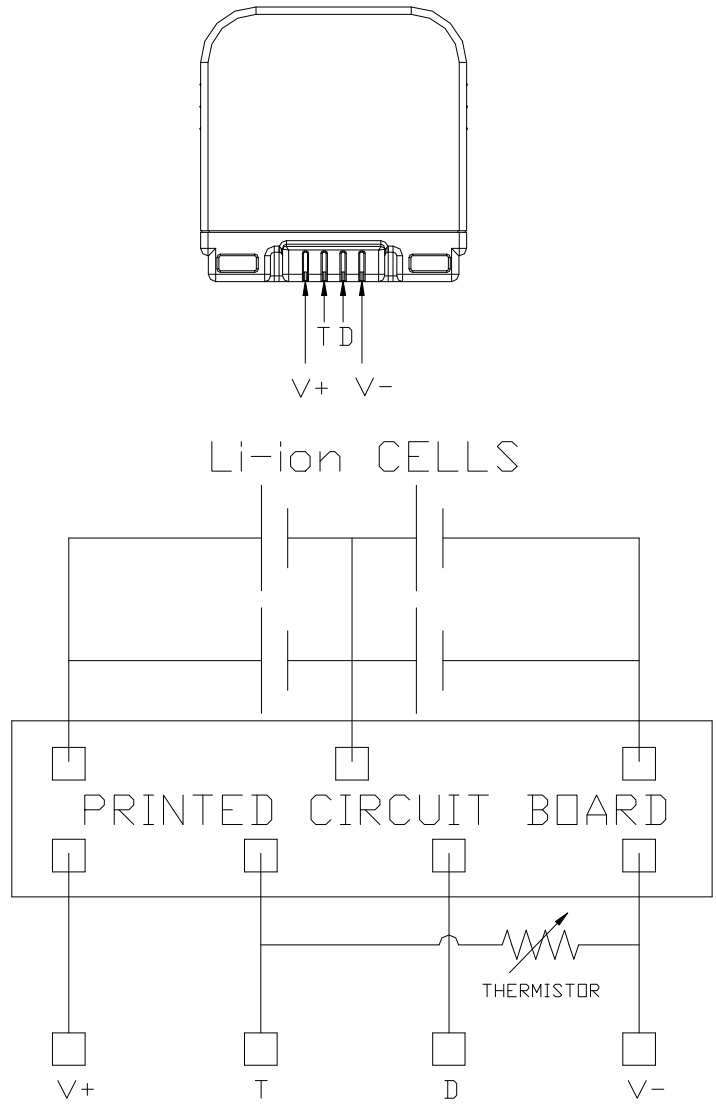

DCV	'V+'-'V-'	7.4V MIN.
THERMISTOR	T-V-	8.3 - 12.1k ohm (20-23°C)
CHECK POINT	SPECIFICATION	

Distributed by:

MICROBATTERY.COM

7350 NW 35th Terrace, Miami, Florida 33122

Customer Service: 1-866-999-2355 Phone: 1-305-371-9200 Fax: 1-305-371-9400

www.microbattery.com

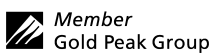

Manufacturer reserves the right to alter or amend the design, model and specification without prior notice.